

# Power-System Frequency and Stability Control using Decentralized Intelligent Loads

Daniel Trudnowski, *Senior Member, IEEE*, Matt Donnelly, *Senior Member, IEEE*, Eric Lightner<sup>1</sup>

**Abstract**—Modern power systems operate on the premise that the load is uncontrollable and that system voltage, frequency and stability are primarily maintained through control of the generation. In this paper, we challenge this premise by proposing a much more active role for intelligent loads specifically related to frequency control and dynamic stability. In modern systems the load is typically only controlled under severe stability conditions via load shedding. Recent research has demonstrated that many loads could cost-effectively become intelligent, allowing for the potential of the loads to more actively participate in system operation and control. The potential benefits of active load control are investigated. Also, reliability and implementation issues are explored. Fundamental analysis and multi-machine system simulation examples are used to demonstrate many of the issues.

**Index Terms**—Frequency control, load management and control, dynamic stability.

## I. INTRODUCTION

THE majority of interconnected power systems operate on the premise that the load is uncontrollable. System voltage, frequency and stability are primarily maintained through the real-time control of the generation. For example, system frequency is controlled through adjustment of the mechanical power of the generators using speed governor feedback and area generation control (AGC) [1]. Similarly, dynamic stability enhancement is conducted through adjustment of the generator's excitation voltage via the power system stabilizer (PSS) loop, and more recently, transmission level FACTS devices [1]. Typically, the load is only controlled under severe stability conditions such as under-frequency load shedding. Traditional system operators view the load as a variable uncontrolled demand, and the generation must constantly adjust to reliably meet the demand. Nobel laureate Vernon Smith puts it this way, "Eighty-five years of regulatory efforts have focused exclusively on supply – leaving on dusty shelves proposals to empower consumer demand, to help stabilize electric systems while creating a more flexible economic environment [2]."

<sup>1</sup> D. Trudnowski is at Montana Tech of the University of Montana, Butte, MT 59701 USA (e-mail: [dtrudnowski@mtech.edu](mailto:dtrudnowski@mtech.edu)). M. Donnelly is at the Pacific Northwest National Laboratory (PNNL), Richland, WA 99352 USA (email: [Matthew.Donnelly@pnl.gov](mailto:Matthew.Donnelly@pnl.gov)). PNNL is operated for the US Department of Energy by Battelle Memorial Institute. E. Lightner is at the US Department of Energy, Washington, DC 20585 USA (email: [eric.lightner@hq.doe.gov](mailto:eric.lightner@hq.doe.gov)).

In this paper, we challenge the premise that load is uncontrollable in the time frame required for frequency control and electromechanical stability by proposing a much more active role for intelligent loads. The potential benefits of active load control are investigated. Also, reliability and implementation issues are explored. Fundamental analysis and multi-machine system simulation examples are used to demonstrate many of the issues.

Recently, the United States Department of Energy initiated a new research program, GridWise [3,4], the primary goal of which is to develop intelligent resources that can improve transmission and distribution reliability, efficiency and security. Further, the authors believe that North American Electric Reliability Council (NERC) operating policy already allows the Regions to count active load control as part of their portfolio of frequency response resources [5].

The goal of this paper is to examine the potential of the intelligent load technologies for improving power system frequency and stability control and to identify the challenges that must be overcome to meet this potential. In examining the potential, we identify the generation and transmission benefits that could be obtained from load control. The examination is conducted using fundamental analysis and specific system examples. From these examples, specific technology challenges related to intelligent load control are hypothesized.

## II. EXAMPLE TEST SYSTEM

To examine load control issues, the example simulation test system shown in Fig. 1 is employed. A modified version of the system was originally developed as a simplified model of the western North American power grid in [15]. It has been used in many publications as a research demonstration model for stability limited issues.

The system consists of major generation buses 17 thru 24. Each generation bus has two generators connected to it; one generator is a fixed-power unit with a constant mechanical power and no speed-governor control (generators 1 thru 8); the other generator is equipped with a traditional speed governor (generators 9 thru 16). Generators 9, 10, 14, and 16 are driven by hydro turbines and generators 11, 12, 13, and 15 are driven by faster acting steam turbines. All generators are equipped with fast-acting voltage regulators and PSS units, and all are modeled using a detailed two-axis transient model.

Simulation data is contained in the Appendix.

The test system has loads connected to buses 31 thru 41 disbursed throughout the system. Each load can be split into a portion consisting of constant impedance, constant current, constant power, and controllable. The baseline line-flows and loads are shown in Fig. 1.

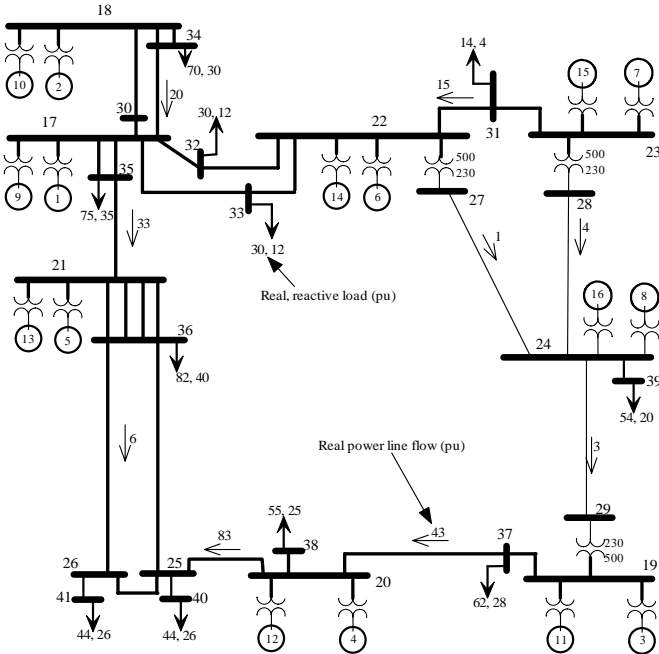

Fig. 1: Example system. Base power is 100 MVA.

### III. LOAD FREQUENCY CONTROL STRATEGY

A simple and arguably optimal control strategy is to linearly modulate load based on frequency error. This will provide a damping torque to electromechanical dynamics and provide improved frequency regulation.

To demonstrate this, consider the traditional swing equation for a given generator

$$2H \frac{d\omega}{dt} = \frac{P_{mech}}{\omega} - \frac{P_{elec}}{\omega} \quad (1)$$

where  $H$  is the generator's per unit inertia constant,  $\omega$  is the per unit speed,  $P_{mech}$  is the mechanical power from a turbine, and  $P_{elec}$  is the generator's electrical output power. Because  $\omega$  is relatively constant, examination of (1) with modulation of  $P_{elec}$  based on speed error results in a damping torque. Also, the larger the modulation, the higher the damping torque. This is a well-established concept and is the fundamental basis for modern power system stabilizer (PSS) design [1].

In the electromechanical frequency range, the generator's output power ( $P_{elec}$ ) is algebraically related to the loads at each bus. We hypothesize that modulation of the load's real power based on the frequency error at the bus results in the appropriate modulation of  $P_{elec}$  at each generator. Adequate proof of this hypothesis requires detailed theoretical analysis, simulation testing, and experimentation. We demonstrate the potential with the following simulation examples.

#### A. Example 1: Control vs. no control

For this simulation example, the system is initially operated at the baseline loading condition. Each fixed-power generator is loaded to 50% of the power produced at that bus. For example, generator 1 produces 50% of the power injected into bus 17, while generator 9 produces the other 50%.

For the controlled case that follows, the real power at each load bus is modulated using the control law

$$\Delta P_k = K_p * \Delta f_k \quad (2)$$

where

$k$  = bus number (31 thru 41),

$\Delta f_k$  = electrical frequency error in Hz at bus  $k$ ,

$\Delta P_k$  = power modulation at bus  $k$  in percent of baseline loading at bus  $k$ ,

$K_p$  = control gain in units percent/Hz.

The unit of measurement for  $\Delta P_k$  is percent of baseline loading; that is, if  $\Delta P_k = 1$ , then 1% of the load is modulated. For the simulation in this example,  $K_p = 100$  and the absolute maximum  $\Delta P_k$  allowed at each bus is  $\pm 20\%$ . Therefore, if the frequency drops to 59.8 Hz, the load will be modulated by 20%.

The simulation consists for two step changes in the load at each load bus to bring the system from the baseline loaded condition to a more heavily loaded condition. The switching actions in terms of time ( $t$ ) are:

$t = 1$  sec. – all real and reactive loads are suddenly increased by 5% of the baseline loading;

$t = 40$  sec. – all real and reactive loads are suddenly increased by 15% of the baseline loading;

The loads are changed using a stepping function to accentuate the effects of the load control. In reality, the loads would slowly change over the course of a day, but the step changes demonstrate the controller performance with a small simulation time. Fig. 2 shows the electrical frequency at bus 25, Fig. 3 shows the voltage at bus 25, and Figs. 4 and 5 show the power flowing from bus 20 to 25 for the simulation.

For the no-control case, the slow-moving portion of the response is caused by the speed governor's attempt to maintain frequency. The frequency does not fully recover after the increased loading because of the droop effect in the speed-governor control. Eventually, the AGC system would increase the swing generators' output to fully recover frequency (typically, this requires several minutes). The higher frequency swings in the no-control case are caused by electromechanical oscillations. As is typical for a stability-limited power system, the oscillations become undamped at the heavier loading indicating unacceptable unstable operation.

As seen in Figs. 2 thru 5, the load control considerably

improves the frequency regulation and stability of the system. Without load control, the second increase in load causes the heavily loaded system to go into an undamped oscillation. With load control, the system is much more stable and has nearly no oscillations and improved voltage regulation. Also, the frequency regulation with load control is much faster and accurate in the steady state. The required power modulation for the results shown in Figs. 2 thru 5 is approximately 11% of the baseline.

This example demonstrates significant potential for using load control for improved frequency regulation and stability improvement. With the load control, the transmission system reliably operates at a higher loading level without stability issues.

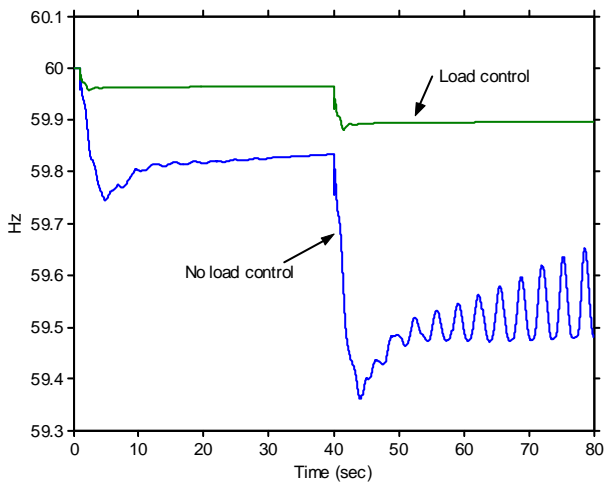

Fig. 2: Bus 25 electrical frequency for example 1.

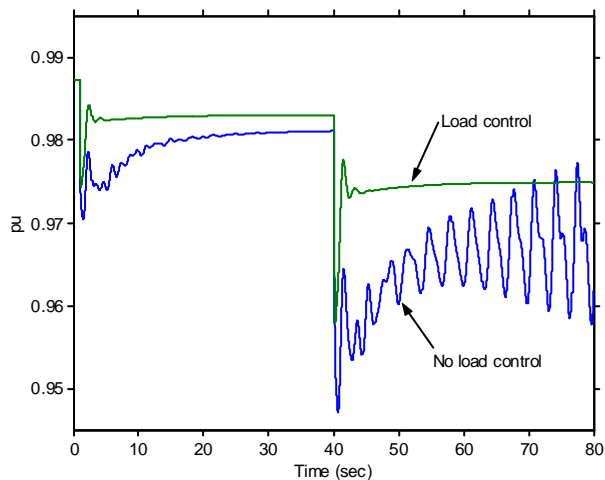

Fig. 3: Bus 25 voltage for example 1.

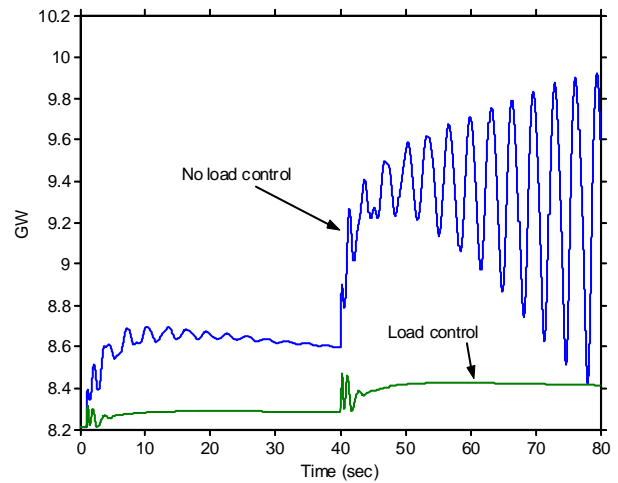

Fig. 4: Real-power flowing from bus 20 to bus 25 for example 1.

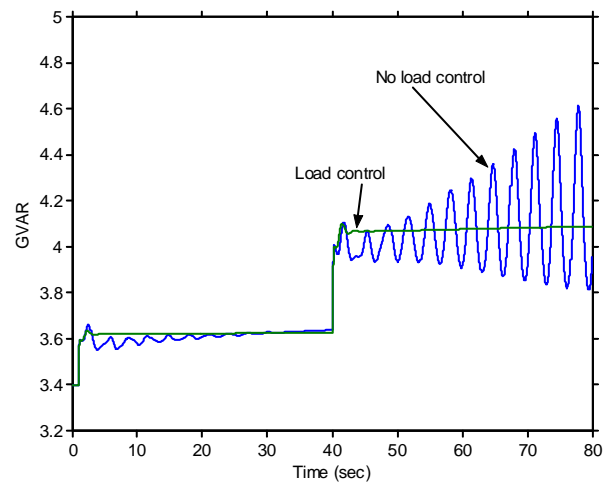

Fig. 5: Reactive power flowing from bus 20 to bus 25 for example 1.

#### IV. REDUCED SPEED GOVERNORS

As shown in the previous example, load control can significantly contribute to the system's frequency regulation. One advantage of this is that fewer generators would require speed governor control, allowing for increased fixed-power loading. This may be of considerable interest to power producers because many power plants operate more efficiently under fixed-power loading. The extent of frequency regulation available from load control is certainly system dependent, but, as the following example demonstrates, the potential is significant.

##### A. Example 2: Speed Governors vs. No Speed Governors

We first simulate the system's response with all generators' fixed-power loaded (i.e., no speed governors are employed and all mechanical powers are set to a constant) and no load control. Fig. 6 shows the system's response to the same disturbances as used in example 1. As expected, the

frequency is unstable and diverging because there is a mismatch in generation and load. If speed governors are used on 50% of the generators, the system's frequency recovers, as shown in the "no control" case in Fig. 2 of example 1 (bus is still unstable). Our goal is to determine the magnitude of load control required to match the 50% speed-governor response using load control and all fixed-power turbines.

The simulation is repeated with load control, with  $K_p = 25$  and the absolute maximum  $\Delta P_k$  allowed at each bus is 20%. The results are shown in Fig. 7. As can be seen, the load control provides similar frequency regulation as the speed governor control. The dynamic stability response of the load control case is stable and has considerable damping. One can improve the regulation by increasing  $K_p$ .

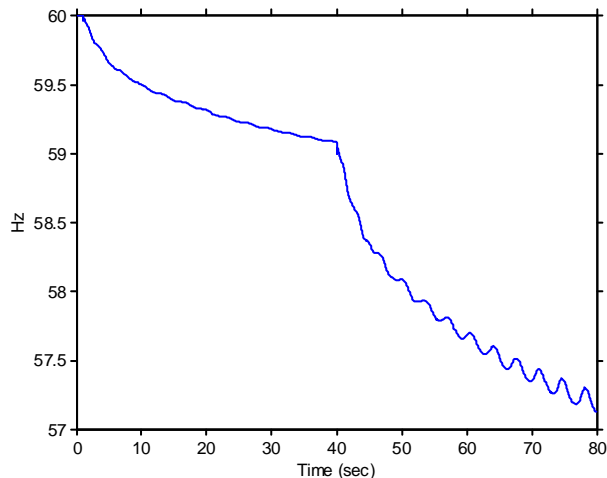

Fig. 6: Bus 25 frequency with no speed governors and no load control for example 2.

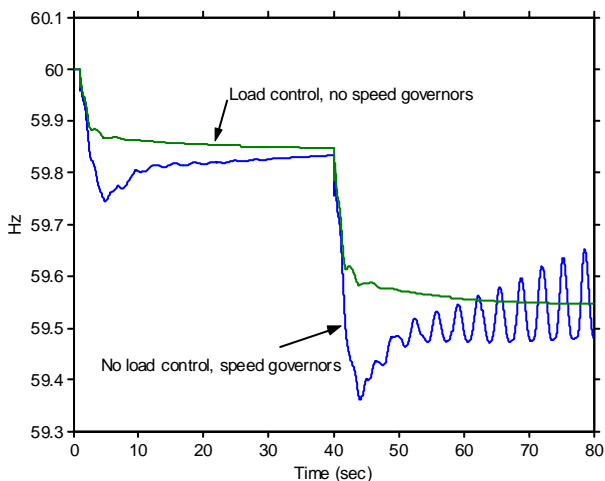

Fig. 7: Bus 25 frequency for example 2.

## V. IMPROVED POWER TRANSFER

For stability-limited systems, improving the dynamic stability of the system provides the opportunity to transfer more power over the same transmissions system. The extent

of increase is highly system dependent, but with load control, the potential can be significant. This is demonstrated in the following example.

### A. Example 3: Improved Power Transfer

Consider the transmission system from bus 18 to 17 in Fig. 1. To maintain reliability, we require that the system must return to a stable condition following a three-phase three-cycle fault on one of the parallel lines between the buses (line 18 to 30). For the baseline loading case and no load control, the results are shown in Fig. 8. As seen in the figure, the system is transient unstable with generators connected to bus 18 losing synchronism with the rest of the system.

The traditional power-planning approach for solving the unstable problem is to reduce the pre-fault line loadings of 2000 MW until a stable response is achieved and then operate the system such that this safe loading level is never exceeded. This is done by adjusting the mechanical power set points of generators 2 and 10. We conducted this process on the simulation system using both load control and no load control. With no load control, the pre-disturbance line loading must be reduced to 780 MW to achieve a marginally stable response. If load control is employed using the same control parameters as example 1, a stable response is achieved at a line loading of 920 MW. Therefore, the load control enables a 18% increase in line loadings.

The system's responses to these two new conditions are shown in Fig. 9. Under both cases, generators connected to bus 18 return to synchronism; but, without load control, the system has a very low frequency lightly-damped electromechanical oscillation indicating the system is still near an unstable condition. With load control, the system has no noticeable oscillations. Many utility engineers would find the no-control oscillations unacceptable and would further decrease the pre-fault loading. As an example, one may have the requirement that the oscillations must be significantly decayed within 20 seconds. To achieve this, the no-control pre-fault loading must be decreased to at least 190 MW; the results from this case are shown in Fig. 10. When compared to the 920 MW loading achieved with load control, the load modulation enables a 380% increase in loading.

One must be cautious not to generalize the results in this example to other systems. All stability-limited cases are unique; but, the example does demonstrate the potential of the concept. A somewhat similar study to this example is contained in [16]. In [16], loads within the southern California portion of a detailed model of the western North American power system are modulated by  $\pm 450$  MW. The modulation dampens north-south system oscillations and enables an additional 400 MW of power transfer on a critical transmission path.

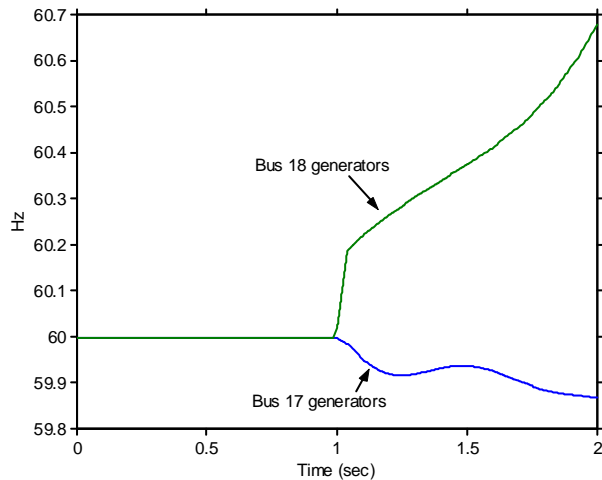

Fig. 8: Generator electrical speeds with the system operated at baseline loading with no load control for example 3.

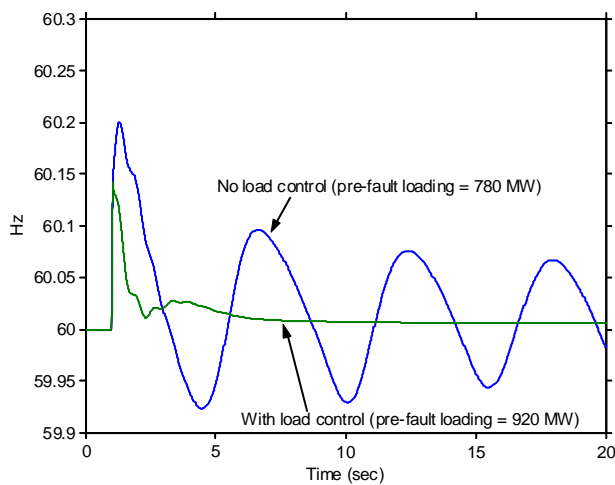

Fig. 9: Bus 18 generators electrical speed with reduced line loading for example 3.

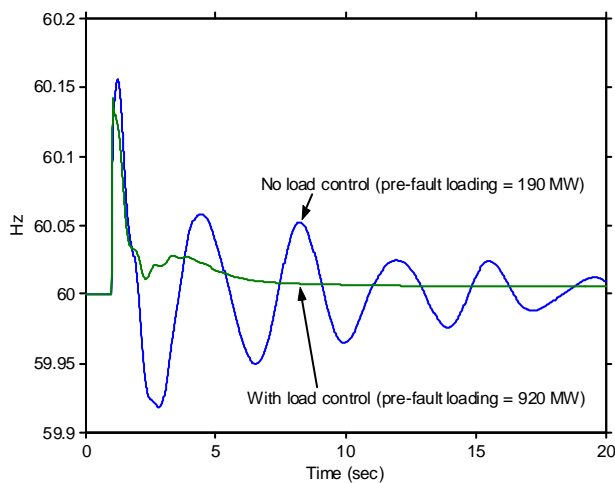

Fig. 10: Bus 18 generators electrical speed with reduced line loading for example 3. Line loading further reduced to provide damping to oscillations.

## VI. LOAD CONTROL FEASIBILITY

The feasibility of implementing the type of active load control considered in this paper can be examined in three parts – the feasibility of achieving the magnitude of resources required to supplant traditional supply-side controls for frequency regulation and stability, the feasibility of using frequency as an input to active loads enabling autonomous control and eliminating the need for expensive communications, and the feasibility of emulating the linear control law (2) using many highly distributed switching actions.

Demonstrating that there is adequate resource availability on the demand side to achieve active load control for frequency regulation and stability has yet to be fully scoped but is relatively easy to hypothesize. Major load management programs have been in place for over 20 years. A sampling of programs from various parts of the world can be found in [6-8]. In fact, nearly every end-use involving temperature control could be used in load management schemes for at least a short duration. These end-use applications include refrigeration, heating, drying, cleaning, etc. In residential applications alone, the authors estimate that up to 2/3 of peak residential load, approximately 20% of system load, can be interrupted for short periods of time with no adverse impact to the consumer. These loads include clothes dryers, where only the heating element is interrupted leaving the drum motor operational; refrigerators, where only the compressor is interrupted leaving the lights operational; HVAC systems, where the thermostat is temporarily set back; cook tops and ranges, where heating elements are interrupted intermittently slightly affecting cooking time; water heaters and a host of other examples. Unlike peak shifting schemes involving load curtailment, the resources required for frequency regulation and stability are only required for up to a few minutes making the trivial inconvenience to the consumer imperceptible. As a result of research into these concepts, Whirlpool Corporation has specified an Appliance Energy API that will guide not only appliance manufactures but designers of any residential product in developing a standard way to receive communications and respond to a load reduction request from a load management system.

Given that an adequate resource exists, a discussion of whether frequency can be used as an input to create an autonomous control action naturally follows. Certainly the experience of under-frequency load shedding provides considerable backdrop to this issue. Charles Concordia's thoughts in a 1995 paper on load shedding invoke the right set of issues. He writes, "To be effective, [under-frequency load shedding] should be automatic, be distributed uniformly across the system at each step to avoid aggravating line overloading, be locally controlled in response to local frequency to be independent of system splitting, and should not be dependent on communication links [9]." Mr. Concordia was writing about a step-wise load shedding scheme, but his thoughts could equally apply to the

continuous load shedding scheme described in this paper. Moreover, researchers have conducted extensive research in adaptive load shedding schemes both with and without communication, for example see [10-12].

A natural extension to a step-wise or adaptive scheme is to implement the load control continuously according to a predetermined statistical distribution of frequency setpoints. At any given time of day, load  $L_1$  may be set to shed at setpoint  $S_1$ .  $L_2$  may be concurrently set to shed at  $S_2$ .  $L_1$  and  $L_2$  may be identical loads, water heaters, for example, but the embedded controllers within these loads select different setpoints according to a predetermined random distribution. The distribution effectively sets the gain  $K_p$  in (2). To ensure equity among all of the participating loads, the setpoints can be redistributed periodically using a random number generator embedded in the controller. Given the abundance of literature on frequency-based load management, the authors conclude that the technique is indeed feasible.

Fewer researchers have investigated the feasibility of achieving the right amount of load reduction in the right location using frequency. The authors in [13] describe “electromechanical wave phenomenon” in which the wave front of a power system disturbance travels at a speed of 500 to 1500 miles per second. The wave front is measured by the drop in frequency resulting from the disturbance. The frequency deviation is tracked as it travels across the US eastern and western grids. Extrapolating from this research the authors conclude that load in the vicinity of the disturbance would shed well before more distant loads, thereby damping the electromechanical wave rather than allowing it to “propagate.”

To expand on this concept of intelligent loads, the United States Department of Energy recently initiated two new research programs: GridWise and GridWorks [3,4]. The primary goal of these programs is to develop intelligent methods to improve T&D reliability and lower energy system costs. One component of the program involves developing system loads that can interact with the T&D system to achieve control objectives. For example, many clothes dryers can work together to achieve a linear control action as viewed from the transmission system.

## VII. BENEFITS, CHALLENGES, AND CONCLUSIONS

The results and discussions presented here open the door to many specific questions and challenges. Certainly, load control offers considerable potential benefits, including:

- improved system stability, and therefore, a more cost-effective transmission system;
- improved frequency regulation that may allow more generators to be operated under baseline loading, and therefore, more efficient power plant operation.

These benefits could likely result in significant cost savings to the electric energy industry. Assuming, that controllable

loads can be developed, many challenges remain before they can reliably be employed for power system operation and control. Challenges related to frequency regulation and dynamic stability include:

- Will the control law (2) always provide improved stability and frequency regulations for all power systems? Is this the best control strategy?
- How closely and reliably can the control law in (2) be implemented using a highly distributed control action down to the consumer level? Related to this: Can frequency error be accurately measured at the distribution level where load “noise” effects can be significant?
- Can load control participate in AGC? Will this require expanding the control law (2) to include communication with the AGC? For example, is it feasible to have an AGC only operate on area generation error and only operate on frequency error when the frequency falls outside a tolerance window? Or could an integral term be added to the control law (2) to affect an action that would allow us to drop the frequency error terms from the AGC equation?

Answering these questions will certainly require significant research. Also, the results of specific study cases will provide critical information on the cost-benefit analysis.

## VIII. APPENDIX

Simulations were conducted using the Power System Toolbox (from Cherry Tree Scientific Software, Ontario, Canada) operating under MATLAB®. System data includes the following.

### Generators:

Gen. #	$S_{base}$ (MVA)	$H$ (sec)	Damp (pu)
1, 9	2750	4.4	1.0
2, 10	7000	4.6	1.5
3, 11	8000	4.0	1.0
4, 12	7000	4.8	1.0
5, 13	4750	4.9	1.5
6, 14	8000	5.0	1.5
7, 15	2600	3.3	1.0
8, 16	4000	2.8	0.5

Generators 1, 2, 6, 8, 9, 10, 14, and 16 have the following constants:  $x_d = 0.9$  pu,  $x'_d = 0.27$  pu,  $T'_{d0} = 9.0$  sec,  $x_q = 0.6$  pu,  $x'_q = 0.27$  pu,  $T'_{q0} = 0.05$  sec. Generators 3, 4, 5, 7, 11, 12, 13, and 15 have the following constants:  $x_d = 1.9$  pu,  $x'_d = 0.27$  pu,  $T'_{d0} = 6.0$  sec,  $x_q = 1.6$  pu,  $x'_q = 0.27$  pu,  $T'_{q0} = 0.8$  sec. All generator transformer impedances are 0.01 pu on the generator base.

### Exciters and PSS units:

All generators are equipped with a type AC4A exciter with transient gain reduction [Kunder]. Generators 3, 5, 11, and 13 have the parameters:  $K_A = 250$ ,  $T_A = 0.03$  sec.,  $V_{max} = 7.0$  pu, and  $V_{min} = -2.0$  pu. The remaining generators have

parameters:  $K_A = 200$ ,  $T_A = 0.04$  sec.,  $V_{max} = 6.0$  pu, and  $V_{min} = -3.0$  pu. The transient gain reduction lag-lead time constants are  $T_B = 12$  sec. (denominator) and  $T_C = 1.0$  sec. (numerator).

All generators are also equipped with a power system stabilizer tuned using the method described in [14]. The block diagram for the PSS unit is

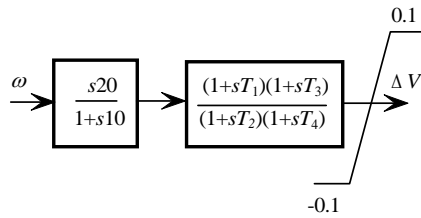

Generators 3, 4, 5, 11, 12, and 13 have  $T_1 = 0.2$  sec.,  $T_2 = 0.02$  sec.,  $T_3 = 0.2$  sec., and  $T_4 = 0.02$  sec. The remaining have  $T_1 = 0.2$  sec.,  $T_2 = 0.02$  sec.,  $T_3 = 0.4$  sec., and  $T_4 = 0.04$  sec.

### Speed Governors and Turbines:

Turbines and speed governors are modeled for generators 9 thru 16 for example 1. The block diagram for the speed governor is

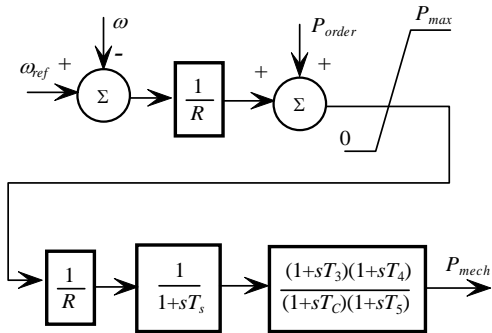

where  $\omega$  is the per unit machine speed,  $\omega_{ref}$  is the machine reference speed,  $P_{order}$  is the reference per unit power, and  $P_{mech}$  is the mechanical power driving the generator. Generators 9, 10, 14, and 16 are modeled as hydro turbines with  $R = 20$  pu,  $P_{max} = 1$  pu,  $T_s = 0.4$  sec,  $T_C = 75$  sec,  $T_3 = 10$  sec,  $T_4 = -2.4$  sec,  $T_5 = 1.2$  sec. Generators 11, 12, 13, and 15 are modeled as turbo-generators with  $R = 20$  pu,  $P_{max} = 1$  pu,  $T_s = 0.04$  sec,  $T_C = 0.2$  sec,  $T_3 = 0$  sec,  $T_4 = 1.5$  sec,  $T_5 = 5$  sec.

### Lines and Transformers:

The impedance of each generator transformer is 0.1 pu on the machine base. The impedance values on a 100 MVA base for the remaining transformers and lines follow.

Bus – bus	Resistance (pu)	Reactance (pu)	Cap. (pu)
17 – 18	0.0019	0.021	0.22
17 – 21	0.003	0.0188	0.018
17 – 22	0.00025	0.00282	0.018
17 – 22	0.0003	0.00279	0.009
19 – 20	0.002	0.0155	0.032
19 – 29	0.0	0.005	0.0
20 – 25	0.0001	0.00075	0.04
21 – 25	0.0063	0.04428	0.292
21 – 26	0.007875	0.05535	0.0

22 – 23	0.0019	0.0255	0.0952
22 – 27	0.0	0.007	0.0
23 – 28	0.0	0.007	0.0
24 – 27	0.008	0.084	0.334
24 – 28	0.0085	0.0995	0.5
24 – 29	0.0092	0.109	0.5
25 – 26	0.0	0.00005	0.0

### IX. ACKNOWLEDGMENT

The authors gratefully acknowledge Mr. Rob Pratt and Mr. Jeff Dagle of Pacific Northwest National Laboratory, and Mr. Steve Hauser for their insights and efforts to move the concept forward. Mr. Gale Horst of Whirlpool Corporation also deserves special thanks.

### X. REFERENCES

- [1] P. Kundur, *Power System Stability and Control*, McGraw Hill, Inc., New York, 1994.
- [2] V. L. Smith and L. Kiesling, "Demand, Not Supply," *The Wall Street Journal*, vol. CCXLII, no. 36, pg. A10, August 20, 2003.
- [3] US Department of Energy, Electric Distribution Transformation Program description. [Online]. Available: [http://electricity.doe.gov/program/electric\\_rd\\_distribution.cfm?section=program&level2=distribution](http://electricity.doe.gov/program/electric_rd_distribution.cfm?section=program&level2=distribution).
- [4] R. Pratt, "Transforming the U.S. Electricity System," presented at the 2004 IEEE Power Systems Conference and Exposition, New York, New York, October 10-13, 2004.
- [5] "Policy 1 – Generation Control and Performance", in *NERC Operating Manual*, North American Electric Reliability Council, February 11, 2003.
- [6] A.S. Davis, "Florida Power Corporation's load management system," *IEEE Computer Applications in Power*, April 1990, pp. 11-15.
- [7] P. Erichsen and N. Haase, "The results from a major load management project," in *Proceedings of the 10<sup>th</sup> International Conference on Electricity Distribution*, Brighton, UK, 8-12 May 1989, pp. 431-436.
- [8] B. Fox and A. McCartney, "Emergency control of frequency on the NIE system," *Power Engineering Journal*, July 1988, pp. 195-201.
- [9] C. Concordia, L.H. Fink and G. Poullikkas, "Load shedding on an isolated system," *IEEE Transactions on Power Systems*, August 1995, pp. 1467-1472.
- [10] P.M. Anderson and M. Mirheydar, "An adaptive method for setting underfrequency load shedding relays," *IEEE Transactions on Power Systems*, May 1992, pp. 647-655.
- [11] V.N. Chuvychin, N.S. Gurov, S.S. Venkata and R.E. Brown, "An adaptive approach to load shedding and spinning reserve control during underfrequency conditions," *IEEE Transactions on Power Systems*, November 1996, pp. 1805-1810.
- [12] B. Qiu, Y. Liu, E.K. Chan and L.J. Cao, "LAN-based control for load shedding," *IEEE Computer Applications in Power*, July 2001, pp. 38-43.
- [13] S. Tsai, L. Zhang, A.G. Phadke, Y. Liu, M.R. Ingram, S.C. Bell, I.S. Grant, D.T. Bradshaw, D. Lubkeman and L. Tang, "Study of global frequency dynamic behavior of large power systems," presented at the 2004 IEEE Power Systems Conference and Exposition, New York, New York, October 10-13, 2004.
- [14] G. Rogers, *Power System Oscillations*, Kluwer Academic Publishers, Boston, Massachusetts, 2000.
- [15] D. J. Trudnowski, J. R. Smith, T. A. Short, and D. A. Pierre, "An Application of Prony Methods in PSS Design for Multimachine Systems," *IEEE Transactions on Power Systems*, vol. 6, no. 2, pp. 118-126, Feb. 1991.
- [16] J. Dagle, D. W. Winiarski, and M. K. Donnelly, "End-Use Load Control for Power System Dynamic Stability Enhancement," Report PNNL-11488, Pacific Northwest National Laboratory, Feb. 1997.